



FORM 3

TEXTILES STUDIES

TIME: 1h 30min

Name: _____

Class: _____

- 1a. Using the templates (*croquis*) below, design **two** pairs of trousers ideal for a casual occasion.
The trousers should have **one** type of pocket. An example has been included to help you.
- b. Sketch a top to match with each trouser.
- c. Colour your designs.
- d. In the box provided, draw a sample of a fabric which can be used for the trousers.
An Example has been included to help you. (3, 3, 3, 3, 4, 2 marks)

2a. Name the marking tools shown in the diagram.

- (i) _____
 (ii) _____ (2 marks)

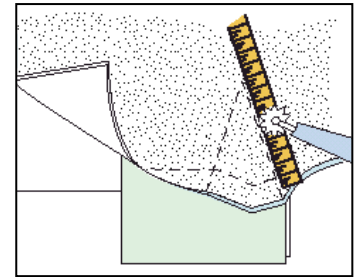

b. Why is this method particularly useful?
 _____ (2 marks)

c. Name and draw **one** other method of marking.

Name _____ **Draw** →

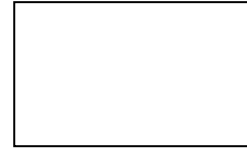

(2 marks)

d. Name and draw **two** common pattern markings.

Give the meaning of each marking.

An example has been done for you.

Name	Marking/Symbol	Meaning
Straight grain	→	Put parallel to selvedge
_____		_____
_____		_____

(2, 2, 2 marks)

3. Stencilling is one method of colouring fabric.

a. With the help of these pictures explain how to prepare and use a stencil to decorate a cushion.



(6 marks)

- (i) _____
 (ii) _____
 (iii) _____
 (iv) _____
 (v) _____
 (vi) _____

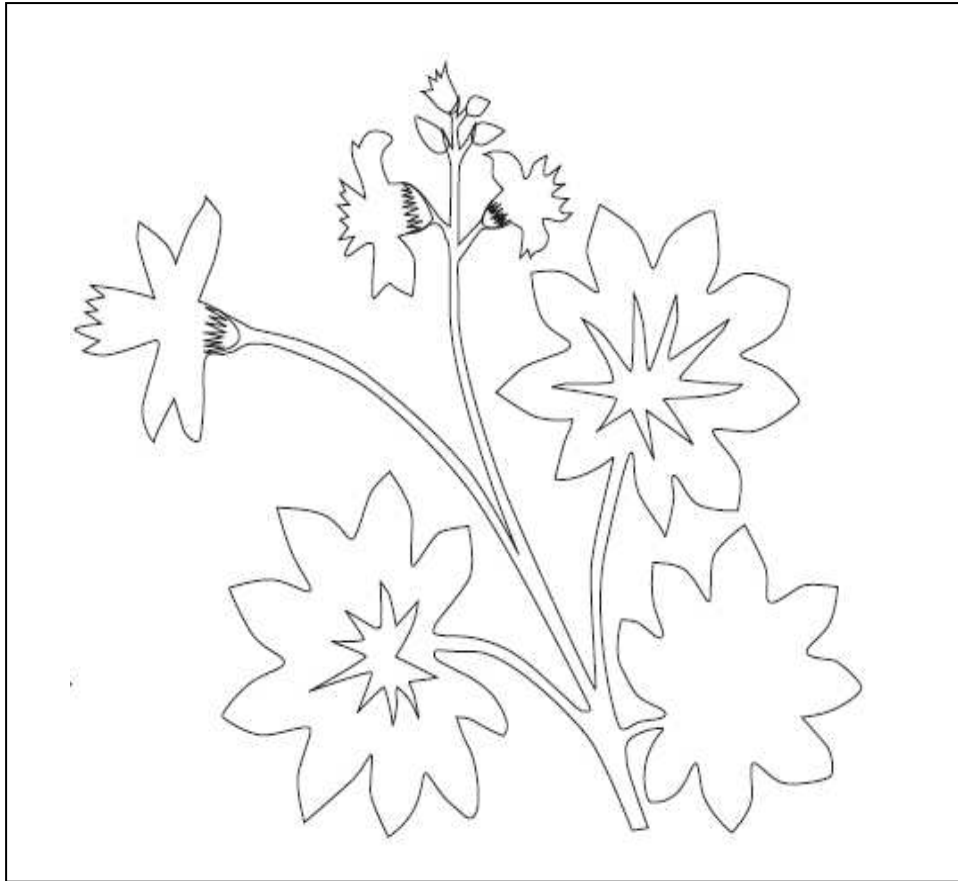

The picture shows the stencil pattern used for the cushion.

b. On the pattern, draw **three** embroidery stitches you can use to emphasize your design. Show clearly where you would use each stitch and name the stitches used. (3, 3 marks)

c. Name **one** other way of colouring fabric.

_____ (1 mark)

d. Name **one** type of dye/paint that can be used for colouring fabrics.

_____ (1 mark)

e. List **three** safety precautions that need to be taken to avoid damage to fabrics and surfaces when colouring fabrics.

(i) _____

(ii) _____

(iii) _____

(3 marks)

Fabrics used for these projects need to be absorbent to be able to absorb the colour properly.

f. Name a suitable fabric that can be used for such a project.

_____ (1 mark)

g. List **two** other properties of this fabric.

(2 marks)

4. The sewing machine is a very important piece of equipment when sewing.

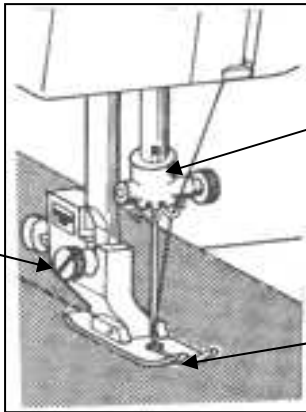

a. Name the **three** marked parts of the sewing machine in the picture.

- (i) _____
- (ii) _____
- (iii) _____

(3 marks)

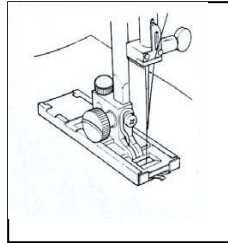

b. Name the sewing machine attachment in the picture.

_____ (1 mark)

c. Why is this attachment (**4b**) important?

 _____ (2 marks)

d. List **three** points to keep in mind when using a sewing machine to keep it in good working order.

- (i) _____
- (ii) _____
- (iii) _____

e. Name and give the use of the piece of equipment in the picture.

Name _____

Use _____



(3 marks)

(1, 2 marks)

f. Name **two** pressing tools from the picture.

Give the use of each tool.

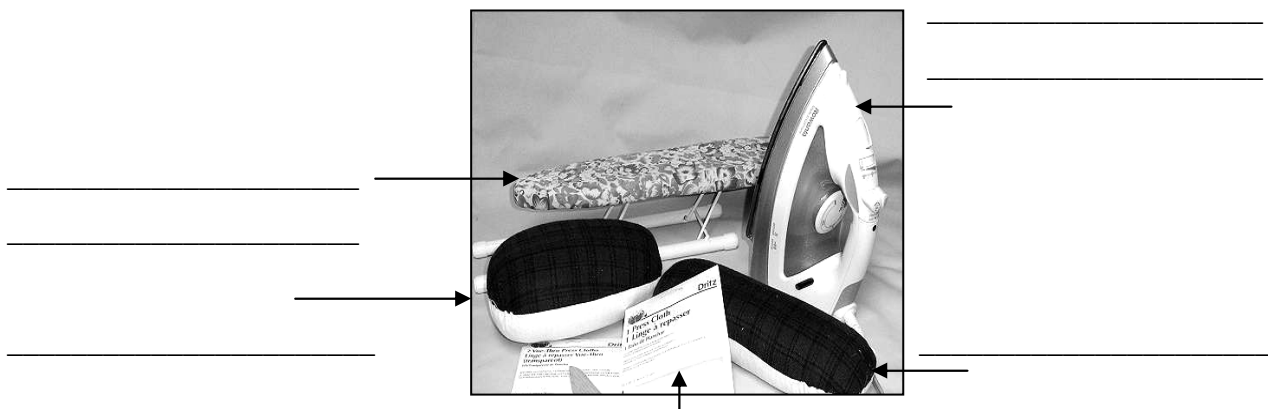

Pressing cloth
 Used for ironing to prevent shine

(2, 4 marks)

5. Seams are used to stitch fabric pieces together.

a. Name the seam shown in the diagrams.

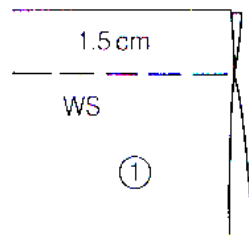

(1 mark)

b. Explain in **five** simple steps how to work the seam.

(i) _____

(ii) _____

(iii) _____

(iv) _____

(v) _____

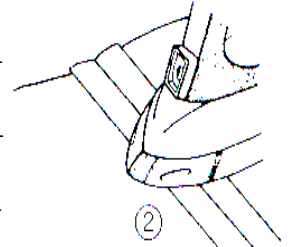

Press open (5 marks)

c. Draw a diagram and name **one** method of neatening this seam.

Draw

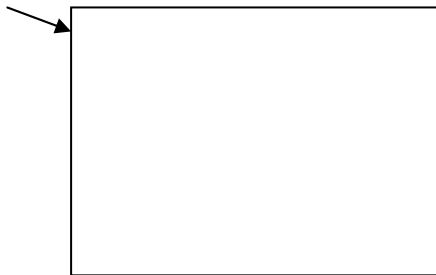

Name _____

(2, 1 marks)

This pocket is often used on jeans.

d. Name the pocket. _____

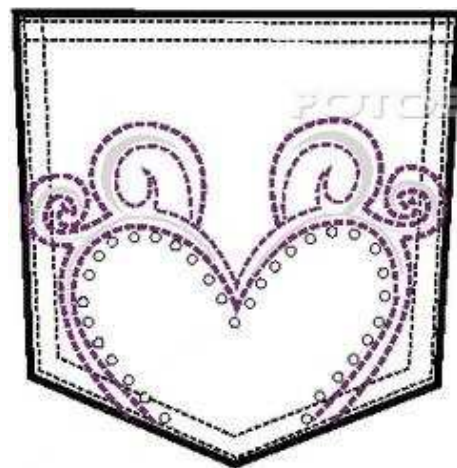

(1 mark)

e. With notes and diagrams, explain how you would make the pocket.

(i) _____

(ii) _____

(iii) _____

(iv) _____

(v) _____



(5 marks)

f. The pocket is decorated with machine embroidery. What can be added to the design to embellish it (*make it nicer*)? Give **two** ideas.

(i) _____

(ii) _____

(2 marks)

Jeans are manufactured from a cotton fabric made with a twill weave.

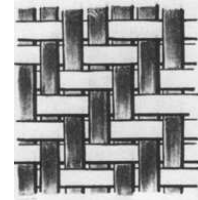

g. Name this cotton fabric. _____

(1 mark)

h. Draw **two** other types of weave and name each weave.

(i) _____

(ii) _____

(i)

(ii)

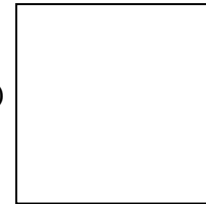
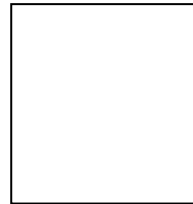

(2, 2 marks)

6. Cotton is a natural fibre widely used for clothing.

a. List **three** properties of cotton.

(3 marks)

b. Name an experiment you have done in class to find out **one** property of cotton.

(1 mark)

c. Using notes and a diagram, explain how you would carry out this experiment.

Diagram

Notes

(2, 4 marks)