

JUNIOR LYCEUM ANNUAL EXAMINATIONS 2009

Directorate for Quality and Standards in Education
Educational Assessment Unit

FORM 2

GRAPHICAL COMMUNICATION

Time: 2 hours

NAME : _____

CLASS : _____

Instructions

- Write your name and class on all sheets.
- Attempt **ALL** questions.
- Answer all questions accurately, using instruments, unless otherwise stated.
- All construction lines **MUST** be left on each solution to show the method used.
- Drawing aids may be used.

Information

- All dimensions are in millimetres.
- Estimate any missing dimension.
- Marks will be awarded for accuracy, clarity and construction.

Question	1	2	3	4	5
Max. mark	36	14	16	16	18
Mark					

1. The figure below shows a pictorial view of a 'SETTING BLOCK'.
 Draw full size, in first angle orthographic projection:
- | | | |
|-----|--|----------|
| (a) | a front elevation as seen from arrow 'A' | 14 marks |
| (b) | a complete plan. (Insert all hidden details) | 13 marks |
- Include the following in your drawing:
- | | | |
|------|---|---------|
| (i) | the symbol of projection used | 2 mark |
| (ii) | in the Name Block provided, print in all the missing items, Name, Date, Title, etc. | 7 marks |

Total 36 marks

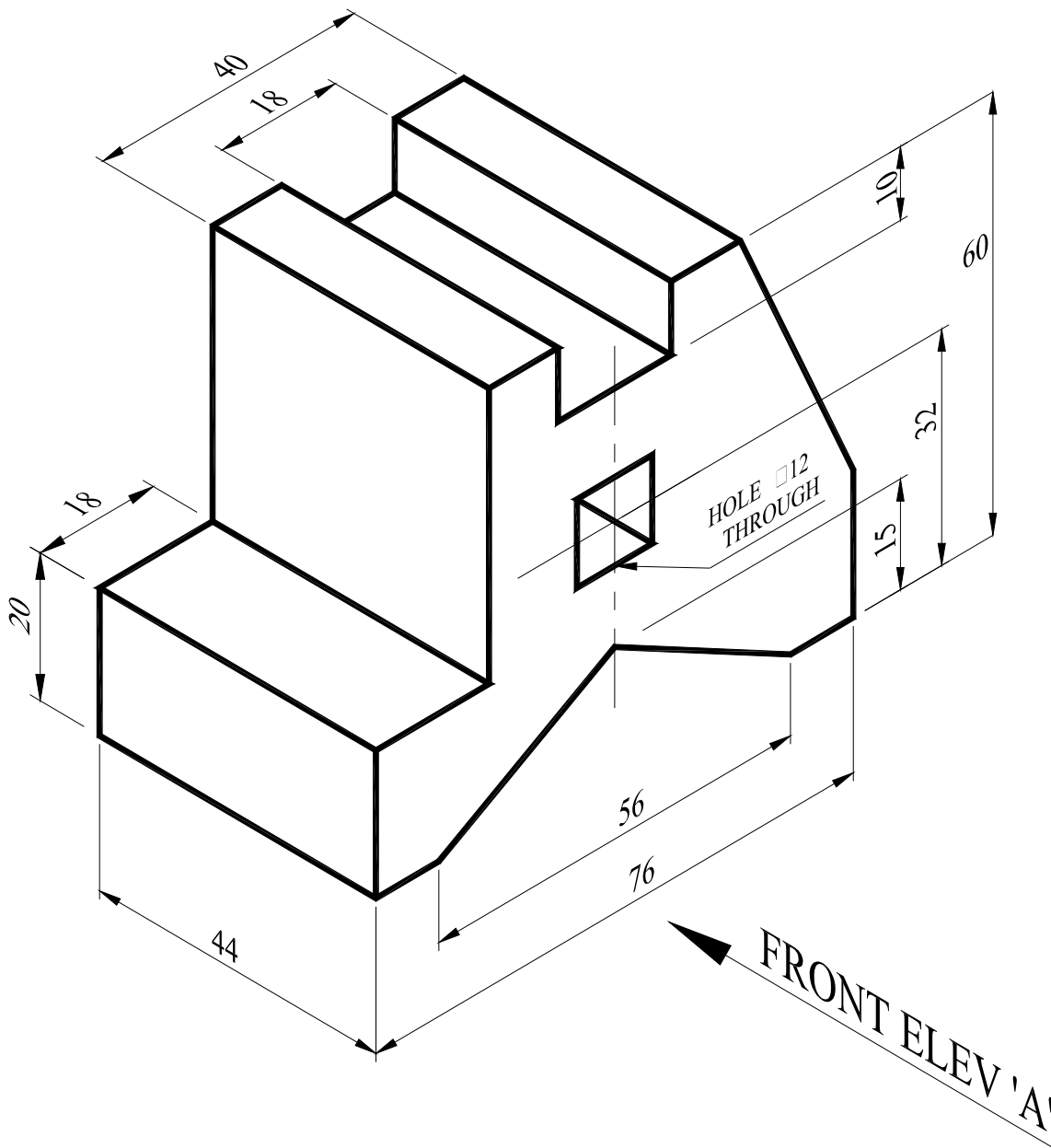

2. The figure below shows three views in first angle orthographic projection and an oblique view of a shaped block.
 Draw, to the dimensions given, an isometric view of the component, making 'X' the lowest corner in your drawing.

14 marks

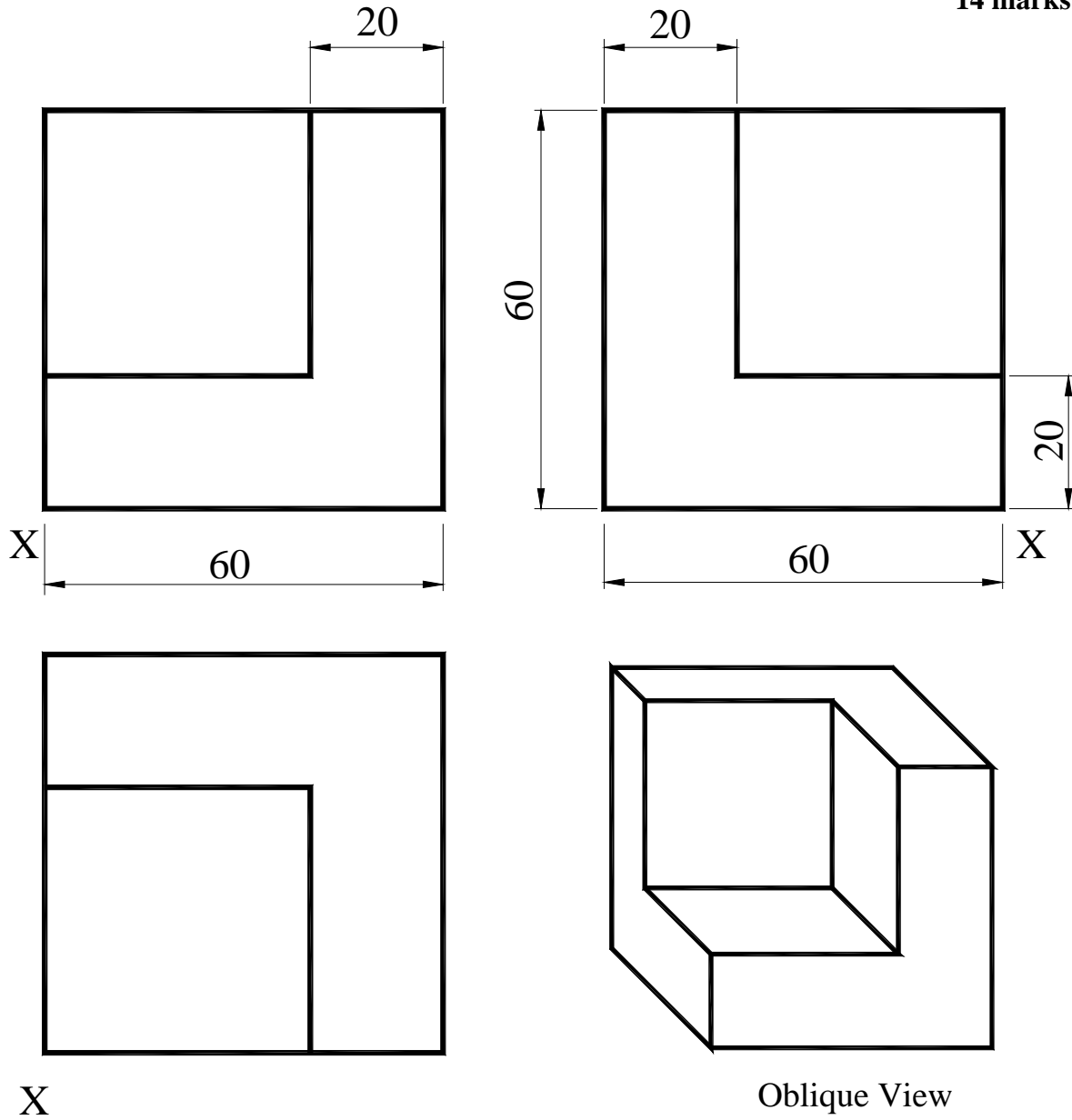

3. The figure below shows a wrought iron triangular frame.
 Within the given triangle on the starter sheet, draw, using geometrical construction, the given pattern.

16 marks

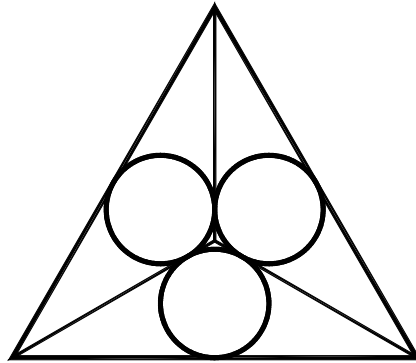

4. Within the given circle shown on the starter sheet, construct geometrically a regular **pentagon**.
 Show all constructional details.

16 marks

5. The drawing below shows a front elevation and an incomplete plan of a hexagonal pyramid.
 Using a scale of full size draw:

- (a) a complete plan
 (b) a one piece development of the whole pyramid not including the base.

18 marks

