

**JUNIOR LYCEUM ANNUAL EXAMINATIONS 2009**  
 Directorate for Quality and Standards in Education  
 Educational Assessment Unit

**FORM 5**

**Physics**

**TIME: 1 hour 45 minutes**

Name: \_\_\_\_\_

Class: \_\_\_\_\_

Answer ALL questions in the spaces provided on the Exam Paper.  
 All working must be shown. The use of a calculator is allowed.  
 Where necessary take the acceleration due to gravity,  $g = 10 \text{ m/s}^2$ .

Equations for Annual Exam Physics

Density	$m = \rho V$	
Pressure	$P = h \rho g$	$P = F/A$
Energy and Work	$PE = m g h$	$KE = \frac{1}{2} m v^2$
	$E \text{ (or } W) = P t$	$W \text{ (or } WD) = F s$
Force	$F = m a$	$W = m g$
Motion	average speed = $\frac{\text{total distance}}{\text{total time}}$	$v = u + a t$
	$s = \frac{(u + v) t}{2}$	$s = \frac{1}{2} a t^2$
	momentum = $m v$	$h = \frac{1}{2} g t^2$
Electricity	$Q = I t$	$W = Q V$
	$V = I R$	$R = R_1 + R_2 + R_3$
	$P = I V = I^2 R = \frac{V^2}{R}$	$R \propto \frac{\text{length}}{\text{area}}$
Electromagnetism	$\frac{N_1}{N_2} = \frac{V_1}{V_2}$	
Heat	$H = m c \Delta \theta$	
Waves and Optics	$c = f \lambda$	$m = \frac{h_i}{h_o} = \frac{\text{image distance}}{\text{object distance}}$

**Marks Grid: For the Examiners' use ONLY**

Question	1	2	3	4	5	6	7	8	Theory	Practical	Total
Max. Mark	8	8	8	8	8	15	15	15	85	15	100
Score											

**Section A.****This Section carries 40 marks**

1. a. The **total mass** of a car, its passengers and their luggage is 1600 kg. Calculate the total weight. **2**
- b. The **total weight** of the car and its passengers is evenly spread across the four tyres. Calculate the weight supported by **each** tyre. **1**
- c. The area of contact of **each** tyre with the ground is  $0.04 \text{ m}^2$ . Calculate the pressure exerted by **each** tyre on the ground. **2**
- d. The driver has to leave the road and drive over a **short distance** across soft damp sandy soil. He thinks that the tyres will sink into the sand and stop the car. One of the passengers suggests letting some air out of each of the tyres.
- i. What effect would this have on the **area of contact of each** tyre with the ground? **1**
- ii. How might **letting out air from the tyres** prevent the wheels from sinking into the sandy soil? **1**
- iii. What **other change** could be made to try to prevent the car from sinking into the sandy soil? **1**

2. Edwin Hubble gathered data on the movement of galaxies, which lead to the discovery of the stunning size of the universe and large number of the star systems. He discovered that the universe is expanding through observations of the wavelength of light emitted from far away galaxies.



- a. Use the words below to complete the following statements:

<b>red shifted</b>	<b>24 hours</b>	<b>365 days</b>	<b>Milky Way</b>	<b>galaxy</b>
--------------------	-----------------	-----------------	------------------	---------------

- i. Planet EARTH spins on its axis once every \_\_\_\_\_ . **1**
- ii. Planet EARTH orbits the Sun once in \_\_\_\_\_ . **1**
- iii. Light coming from far away galaxies is \_\_\_\_\_ . **1**
- iv. A \_\_\_\_\_ is a group of stars. **1**
- v. Our solar system is in the \_\_\_\_\_ galaxy. **1**

2. b. Figure 1 below shows two satellites **A** and **B** orbiting EARTH along two different orbits.

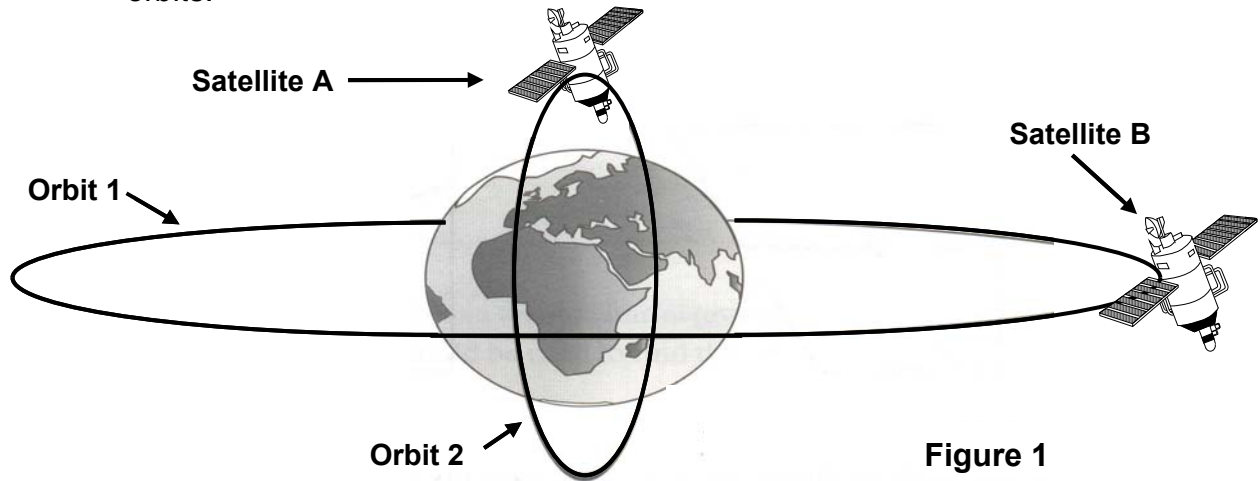

- i. Satellite B is a \_\_\_\_\_ satellite 1
- ii. Satellite \_\_\_\_\_ is following a Polar orbit. 1
- iii. Suggest one possible use of satellite B. 1
- 

3. a. Timothy lifts a load of 50 N from the ground to the roof of his sister's house by means of a rope, through a height of 10 m in 5 s **at constant speed**.  
**Find the:**
- i. **work done** in joules by Timothy in lifting the load, 1
- ii. **power** in watts with which the load is raised, 1
- iii. **potential energy** in joules gained by the load at the top given that its mass is 5 kg, 1
- iv. **final kinetic energy** in joules of the load, if the rope breaks at the top. Assume no air resistance. \_\_\_\_\_ J 1
- v. **final velocity** of the load in m/s if the rope breaks at the top and assuming no air resistance. 1

3. b. Fossil fuels like coal cause pollution and is a non-renewable source of energy.
- Why are fossil fuels described as **non-renewable** sources of energy? 1
  - What are **renewable sources** of energy? 1
  - Give an example of a **renewable** source of energy. \_\_\_\_\_ 1

4. a. Figure 2 shows a ray of light passing through a rectangular glass block.

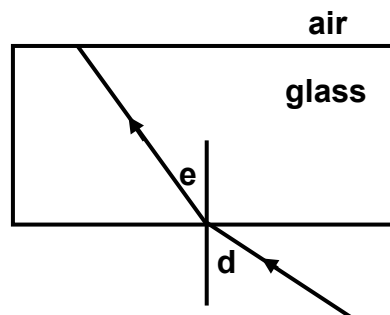

Figure 2

- Complete the path of the ray of light out of the glass block 1
- Angle **d** is the angle of \_\_\_\_\_. 1
- Angle **e** is the angle of \_\_\_\_\_. 1

4. b. Figure 3 represents a ray of light incident at the curved edge of a semicircular glass block.

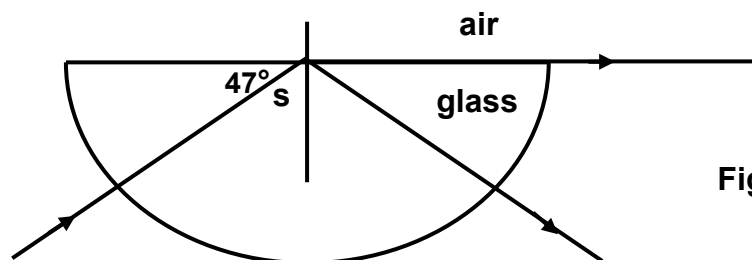

Figure 3

- The angle of refraction in air at the plane surface is \_\_\_\_\_° 1
- Angle **s** is referred to as the \_\_\_\_\_ angle of the semicircular glass block. 1
- Calculate angle **s**. 1
- State what happens when the angle **s** is increased (gets bigger). 1
- Name **one** practical use of the kind of reflection obtained when angle **s** is increased. 1

5. Figure 4 represents a number of electrical components arranged in a circuit.

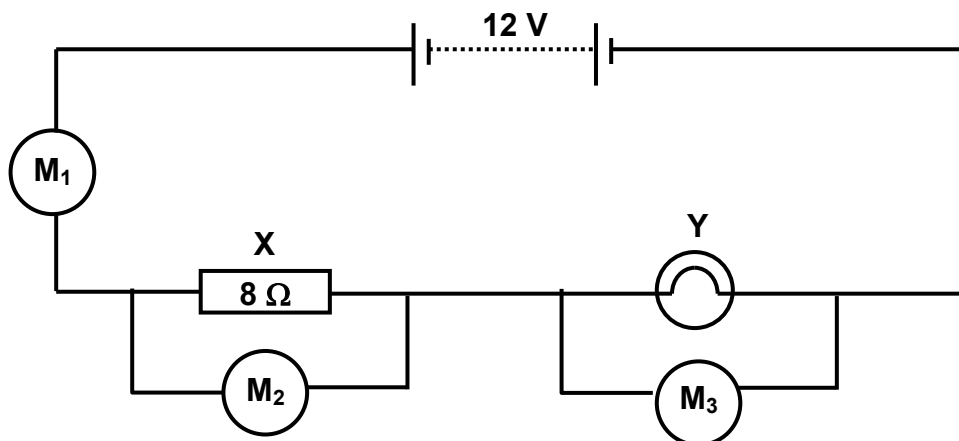

Figure 4

- a. i. Meter  $M_1$  is an ammeter measuring \_\_\_\_\_ through the circuit 1
- ii. Meter  $M_2$  is a \_\_\_\_\_ measuring the potential difference across the  $8\text{-}\Omega$  resistor X. 1
- iii. Electrical component Y is a \_\_\_\_\_ . 1
- iv. Electrical components X and Y are connected in \_\_\_\_\_ . 1
- b. The electric current flowing through the circuit in figure 4 is  $0.5\text{ A}$ . Calculate the:
- i. **potential difference** across the  $8\text{-}\Omega$  resistor X in volts, 1
- ii. **potential difference** across the electrical component Y in volts, 1
- iii. **resistance** of electrical component Y in  $\Omega$ , 1
- iv. **power** generated by the battery through the circuit in Watts. 1

**Section B.****This section carries 45 marks****6. This question is about Hooke's Law.**

- a. You are asked to find out how the extension of a steel spring changes as different loads are added on to the mass hanger attached to the spring.

You are provided with the following apparatus:

a steel spring, a paper pointer, a mass hanger, a half-meter ruler, a stand and clamp, a set of 1 N weights.

Your answer should include:

- i. a **labelled** diagram of the experimental set up, **4**

- ii. a **very** brief description of the method, **2**

- b. Andrew carried out this experiment and obtained the following results:

<b>Load W/N</b>	0.0	1.0	2.0	3.0	4.0	5.0	6.0	7.0	8.0	9.0
<b>Extension e/cm</b>	0.0	0.5	1.0	1.5	2.0	2.5	3.3	4.5	6.1	9.5

- i. Plot a graph of extension (y-axis) against load (x-axis) on the graph paper **5**  
provided.
- ii. On your graph, mark the elastic limit of the spring with the letter 'E.' **1**
- iii. From your graph or otherwise, determine the greatest load which can be **1**  
applied to the spring without damaging it. \_\_\_\_\_.
- iv. The mass hanger causes an extension of 0.5 cm. Calculate its mass in kg. **1**
- v. The natural length of the spring is 10 cm. Calculate its approximate length **1**  
in cm when a load of 3.5 N is applied to it

7. This question is about motion and momentum.

The graph (Figure 5 below), shows the motion of a test car having dummy driver (not real live driver) **wearing a seat belt** crashing into a steel wall.

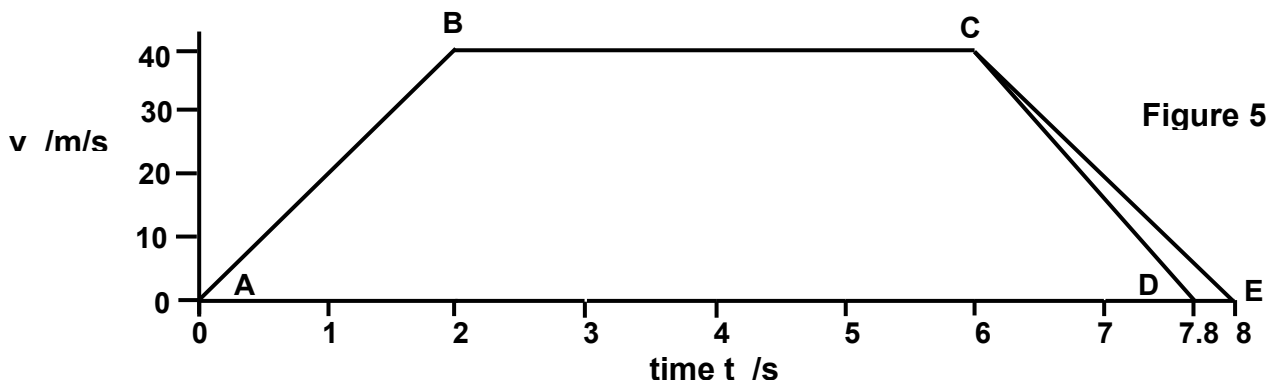

**Point C** on the graph represents the moment **the car crashes** into the steel wall.

**Point D** on the graph represents the moment **the car** comes to a complete stop.

**Point E** on the graph represents the moment **the driver** comes to a complete stop.

- a. i. The **car and its driver** crashed into the steel wall \_\_\_\_\_ s after the beginning of the journey. **1**
- ii. The **car and the driver** crashed into the steel wall at a velocity of \_\_\_\_\_ m/s. **1**
- iii. Calculate the **distance** in meters, covered by the car during **constant velocity**. **2**
- b. i. The time taken for the **car** to come **to rest after** impact at C is \_\_\_\_\_ s. **1**
- ii. The time taken for the **driver** to come **to rest after** impact at C is \_\_\_\_\_ s. **1**
- iii. State why the car does not come **immediately to rest** after impact at C. **1**
- iv. Why does the **driver take longer time** to come to rest after impact? **1**
- c. **Calculate the:**
- i. **momentum** of the **dummy driver** in kgm/s just before impact at C given that its mass is 80 kg; **2**
- ii. **momentum** of the **dummy driver** when at **rest** after impact; \_\_\_\_\_ **1**
- iii. **impact force F** in N **on the dummy driver** if it comes completely to rest at **D**; **2**
- iv. **impact force F** **on the dummy driver** if it comes completely to rest at **E**. **1**
- d. What **conclusion** can you draw from your answers to c. iii and c. iv? **1**

8. This Question is about Magnets and Electromagnetism.

a. Figure 6 below shows the magnetic field of a bar magnet.

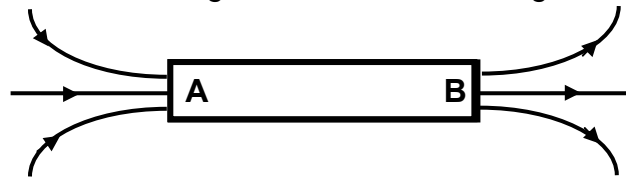

Figure 6

- i. End \_\_\_\_\_ of the bar magnet is its north pole. 1
- ii. End \_\_\_\_\_ of the bar magnet is its south pole. 1
- iii. Briefly explain your answers to i and ii above. 1
  
- iv. The apparatus required to check magnetic polarities is the \_\_\_\_\_. 1
- v. All magnets, whatever their shape have two different and opposite \_\_\_\_\_. 1
- vi. Like magnetic poles \_\_\_\_\_. 1
- vii. \_\_\_\_\_ magnetic poles attract. 1

b. Figure 7 shows a long wire PQ carrying a d.c. current **I**.

- i. Indicate on figure 7 the positive terminal (+) and the negative terminal (-) of the d.c. supply. 1
- ii. Draw the magnetic field pattern due to current **I** flowing through the wire PQ. 1
- iii. Indicate the direction of the magnetic field due to the current flowing through PQ. 1
- iv. **State which rule** you used to answer question iii. 1

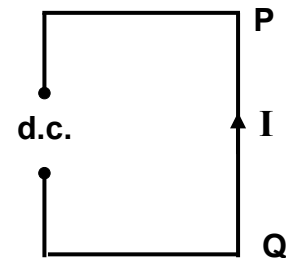

Figure 7

c. Figure 8 below shows a circuit containing a solenoid placed near an unmagnetised iron bar freely hanging from a support.

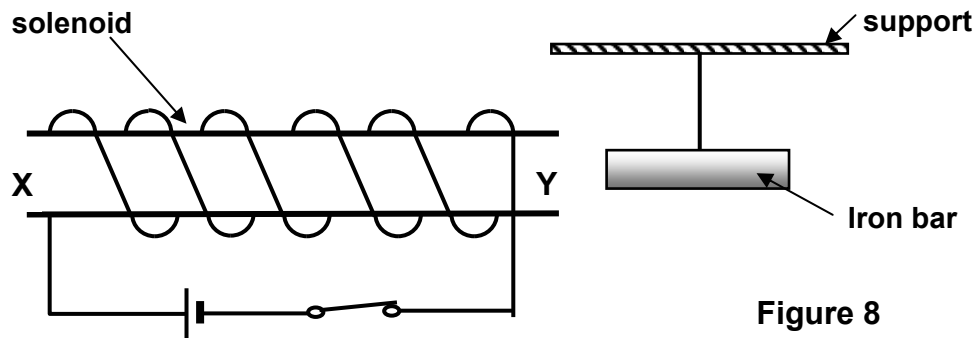

Figure 8

- i. When the current is turned on end \_\_\_\_\_ of the solenoid acts like a north pole of a bar magnet, 1
- ii. While the current in the solenoid circuit is turned on, the iron bar becomes \_\_\_\_\_ 1
- iii. What happens to the iron bar when the current is turned off? 1
  
- iv. State what happens if a steel bar is used instead of the iron bar, when the current is turned off. 1