

SECONDARY SCHOOL ANNUAL EXAMINATIONS 2009

Directorate for Quality and Standards in Education
Educational Assessment Unit

FORM 5

Physics

TIME: 1 hour 45 minutes

Name: _____

Class: _____

Answer ALL questions in the spaces provided on the Exam Paper.
All working must be shown. The use of a calculator is allowed.
Where necessary take the acceleration due to gravity, $g = 10 \text{ m/s}^2$.

Equations for Annual Exam Physics

Density	$m = \rho V$	
Pressure	$P = h \rho g$	$P = F/A$
Energy and Work	$PE = m g h$	$KE = \frac{1}{2} m v^2$
	$E \text{ (or } W) = P t$	$W \text{ (or } WD) = F s$
Force	$F = m a$	$W = m g$
Motion	average speed = $\frac{\text{total distance}}{\text{total time}}$	$v = u + a t$
	$s = \frac{(u + v) t}{2}$	$s = \frac{1}{2} a t^2$
	momentum = $m v$	$h = \frac{1}{2} g t^2$
Electricity	$Q = I t$	$W = Q V$
	$V = I R$	$R = R_1 + R_2 + R_3$
	$P = I V = I^2 R = \frac{V^2}{R}$	$R \propto \frac{\text{length}}{\text{area}}$
Electromagnetism	$\frac{N_1}{N_2} = \frac{V_1}{V_2}$	
Heat	$H = m c \Delta\theta$	
Waves and Optics	$c = f \lambda$	$m = \frac{h_i}{h_o} = \frac{\text{image distance}}{\text{object distance}}$

Marks Grid: For the Examiners' use ONLY

Question	1	2	3	4	5	6	7	8	Theory	Practical	Total
Max. Mark	8	8	8	8	8	15	15	15	85	15	100
Score											

Section A.**This Section carries 40 marks**

1. a. The **total mass** of a car, its passengers and their luggage is 1600 kg. Calculate the total weight. **2**
- b. The **total weight** of the car and its passengers is evenly spread across the four tyres. Calculate the weight supported by **each** tyre. **1**
- c. The area of contact of **each** tyre with the ground is 0.04 m^2 . Calculate the pressure exerted by **each** tyre on the ground. **2**
- d. The driver has to leave the road and drive over a **short distance** across soft damp sandy soil. He thinks that the tyres will sink into the sand and stop the car. One of the passengers suggests letting some air out of each of the tyres.
- i. What effect would this have on the **area of contact of each** tyre with the ground? **1**
- ii. How might **letting out air from the tyres** prevent the wheels from sinking into the sandy soil? **1**
- iii. What **other change** could be made to try to prevent the car from sinking into the sandy soil? **1**

2. Edwin Hubble gathered data on the movement of galaxies, which lead to the discovery of the stunning size of the universe and large number of the star systems. He discovered that the universe is expanding through observations of the wavelength of light emitted from far away galaxies.



- a. Use the words below to complete the following statements:

red shifted	24 hours	365 days	Milky Way	galaxy
--------------------	-----------------	-----------------	------------------	---------------

- i. Planet EARTH spins on its axis once every _____ . **1**
- ii. Planet EARTH orbits the Sun once in _____ . **1**
- iii. Light coming from far away galaxies is _____ . **1**
- iv. A _____ is a group of stars. **1**
- v. Our solar system is in the _____ galaxy. **1**

2. b. Figure 1 below shows two satellites **A** and **B** orbiting EARTH along two different orbits.

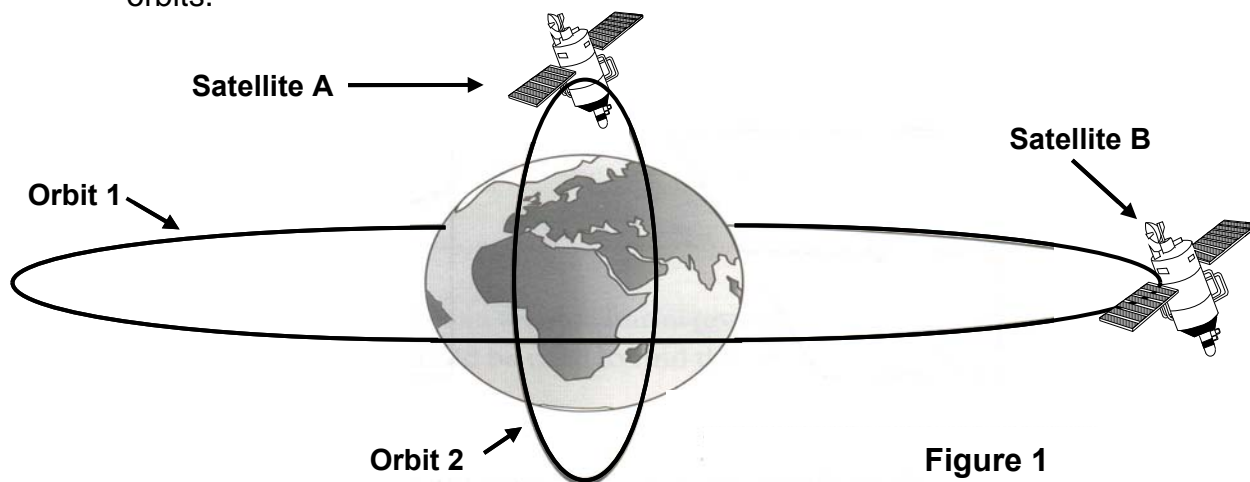

Figure 1

- i. Satellite B is a _____ satellite 1
- ii. Satellite _____ is following a Polar orbit. 1
- iii. Suggest one possible use of satellite B. 1
-

3. a. Timothy lifts a load of 50 N from the ground to the roof of his sister's house by means of a rope, through a height of 10 m in 5 s **at constant speed**.
Find the:
- i. **work done** in joules by Timothy in lifting the load, 1
- ii. **power** in watts with which the load is raised, 1
- iii. **potential energy** in joules gained by the load at the top given that its mass is 5 kg, 1
- iv. **final kinetic energy** in joules of the load, if the rope breaks at the top. Assume no air resistance. _____ J 1
- v. **final velocity** of the load in m/s if the rope breaks at the top and assuming no air resistance. 1

3. b. Fossil fuels like coal cause pollution and is a non-renewable source of energy.
- Why are fossil fuels described as **non-renewable** sources of energy? 1
 - What are **renewable sources** of energy? 1
 - Give an example of a **renewable** source of energy. _____ 1

4. a. Figure 2 shows a ray of light passing through a rectangular glass block.

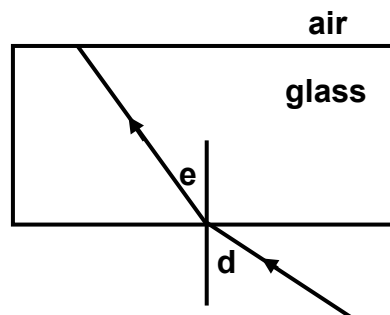

Figure 2

- Complete the path of the ray of light out of the glass block 1
- Angle **d** is the angle of _____. 1
- Angle **e** is the angle of _____. 1

4. b. Figure 3 represents a ray of light incident at the curved edge of a semicircular glass block.

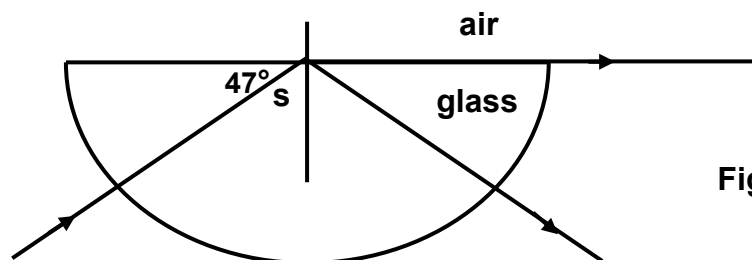

Figure 3

- The angle of refraction in air at the plane surface is _____°. 1
- Angle **s** is referred to as the _____ angle of the semicircular glass block. 1
- Calculate angle **s**. 1
- State what happens when the angle **s** is increased (gets bigger). 1
- Name **one** practical use of the kind of reflection obtained when angle **s** is increased. 1

5. Figure 4 represents a number of electrical components arranged in a circuit.

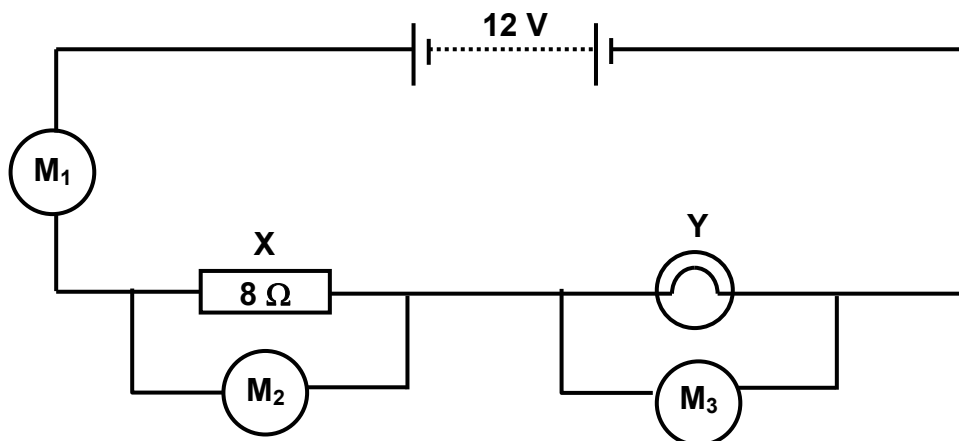

Figure 4

- a. i. Meter M_1 is an ammeter measuring _____ through the circuit 1
- ii. Meter M_2 is a _____ measuring the potential difference across the $8\text{-}\Omega$ resistor X. 1
- iii. Electrical component Y is a _____ . 1
- iv. Electrical components X and Y are connected in _____ . 1
- b. The electric current flowing through the circuit in figure 4 is 0.5 A . Calculate the:
- i. **potential difference** across the $8\text{-}\Omega$ resistor X in volts, 1
- ii. **potential difference** across the electrical component Y in volts, 1
- iii. **resistance** of electrical component Y in Ω , 1
- iv. **power** generated by the battery through the circuit in Watts. 1

Section B.

This section carries 45 marks

6. This question is about Hooke's Law.

- a. Martha set up the necessary apparatus to find out how the extension of a steel spring changes as different loads are added on to the mass hanger attached to it.

Martha was provided with the following apparatus:

a steel spring, a paper pointer, a mass hanger, a half-meter ruler, a stand and two clamps, a set of 1-N weights.

Label the diagram of Martha's experimental set-up.

6

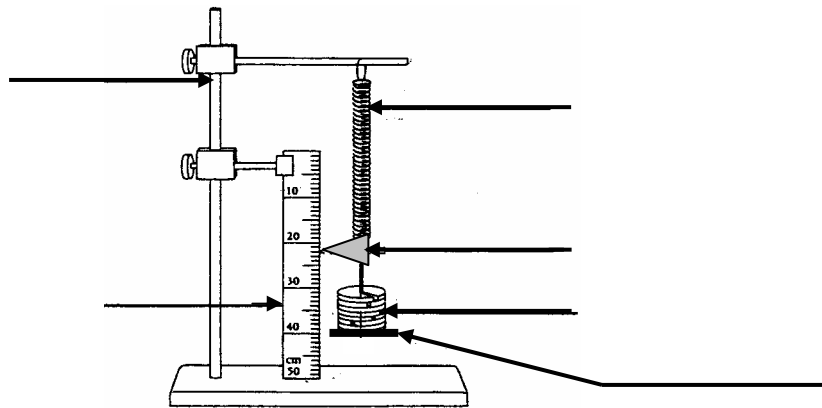

- b. Andrew carried out this experiment and obtained the following results:

Load W /N	0.0	1.0	2.0	3.0	4.0	5.0	6.0	7.0	8.0	9.0
Extension e /cm	0.0	0.5	1.0	1.5	2.0	2.5	3.3	4.5	6.1	9.5

- i. Plot a graph of extension (y-axis) against load (x-axis) on the graph paper provided. **6**
- ii. On your graph, mark the elastic limit of the spring with the letter 'E.' **1**
- iii. From your graph or otherwise, determine the greatest load which can be applied to the spring without damaging it. _____. **1**
- iv. The mass hanger causes an extension of 0.5 cm. Find its weight in newtons. **1**

7. This question is about motion and momentum.

The graph (Figure 5 below), shows the motion of a test car crashing into a steel wall.

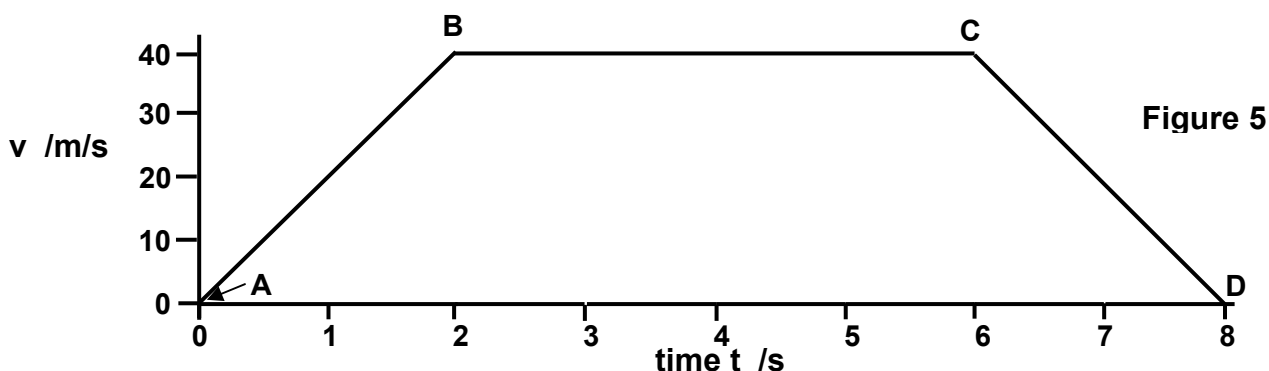

Point C on the graph represents the moment **the car crashes** into the steel wall.

Point D on the graph represents the moment **the car comes to a complete stop**.

- a. From the graph find the:
- i. initial velocity **u** of the test car at A, _____ m/s 1
 - ii. final velocity **v** of the test car at B, _____ m/s 1
 - iii. the time taken during acceleration along AB, _____ s 1
 - iv. acceleration in m/s^2 of the test car along AB. 2
- b. Use the graph to complete the following:
- i. The **car** crashed into the steel wall _____ s after the beginning of the journey. 1
 - ii. The **car** crashed into the steel wall at a velocity of _____ m/s. 1
- c. Use the graph to calculate the **distance** in meters, covered by the car during **constant velocity**. 3
- d. i. Calculate the momentum of the test car in kgm/s , just before impact at C given that its mass is 1000 kg. 1
- ii. What is the momentum of the car after it came to rest? _____ kgm/s . 1
- iii. The time taken for the **car** to come **to rest after** impact at C is _____ s. 1
- iv. Calculate the impact force **F in N** during the collision on the car from: 2

$$F = \frac{\text{change in momentum}}{\text{time}}$$

8. This Question is about Magnets and Electromagnetism.

a. Figure 6 below shows the magnetic field of a bar magnet.

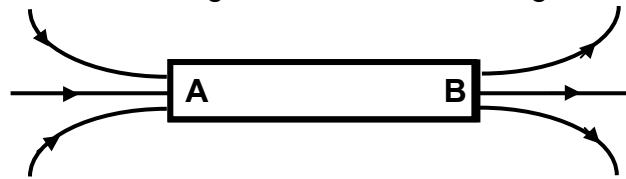

Figure 6

- i. End _____ of the bar magnet is its north pole. 1
- ii. End _____ of the bar magnet is its south pole. 1
- iii. The apparatus required to check magnetic polarities is the _____. 1
- iv. All magnets, whatever their shape have two different and opposite _____. 1
- v. Like magnetic poles _____. 1
- vi. _____ magnetic poles attract. 1

b. Figure 7 shows a long wire PQ carrying a d.c. current I .

- i. Indicate on figure 7 the positive terminal (+) and the negative terminal (-) of the d.c. supply.
- ii. Draw the magnetic field pattern due to current I flowing through the wire PQ.
- iii. Indicate the direction of the magnetic field due to the current flowing through PQ.
- iv. **State which rule** you used to answer question iii.

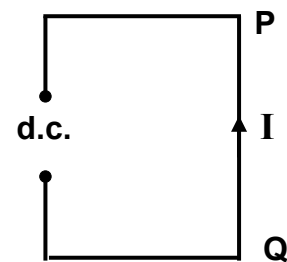

Figure 7

- 1
- 2
- 1
- 1

c. Figure 8 below shows a circuit containing a solenoid placed near an unmagnetised iron bar freely hanging from a support.

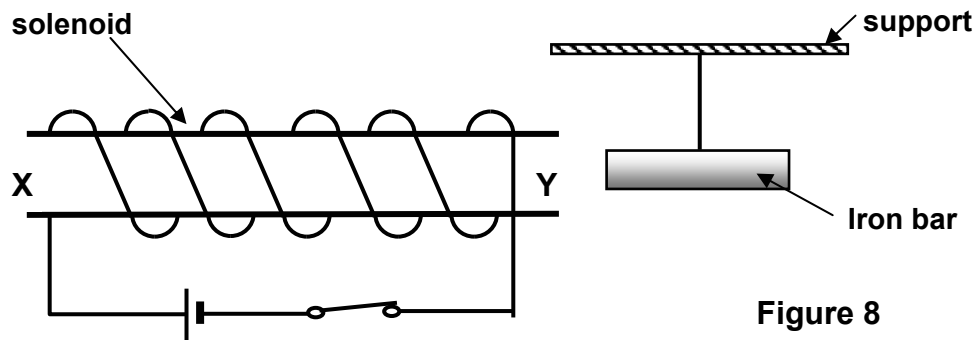

Figure 8

- i. When the current is turned on, end X of the solenoid acts like a _____ pole of a bar magnet, 1
- ii. While the current in the solenoid circuit is turned on, the _____ bar becomes magnetised. 1
- iii. What happens to the iron bar when the current is turned off? 1
- iv. State what happens if a steel bar is used instead of the iron bar, when the current is turned off. 1